



Calhoun: The NPS Institutional Archive
DSpace Repository

Theses and Dissertations

1. Thesis and Dissertation Collection, all items

1994-03

A computer-assisted final examination scheduling system for the Naval Postgraduate School

Golmayo, Pedro F.

Monterey, California. Naval Postgraduate School

<http://hdl.handle.net/10945/30912>

This publication is a work of the U.S. Government as defined in Title 17, United States Code, Section 101. Copyright protection is not available for this work in the United States.

Downloaded from NPS Archive: Calhoun



Calhoun is the Naval Postgraduate School's public access digital repository for research materials and institutional publications created by the NPS community. Calhoun is named for Professor of Mathematics Guy K. Calhoun, NPS's first appointed -- and published -- scholarly author.

Dudley Knox Library / Naval Postgraduate School
411 Dyer Road / 1 University Circle
Monterey, California USA 93943

<http://www.nps.edu/library>

NAVAL POSTGRADUATE SCHOOL
Monterey, California



THESIS

A COMPUTER-ASSISTED
FINAL EXAMINATION SCHEDULING SYSTEM
FOR THE NAVAL POSTGRADUATE SCHOOL

by

Pedro F. Golmayo

March, 1994

Thesis Advisor:

Gordon H. Bradley

Approved for public release; distribution is unlimited.

Thesis
G5463

DUDLEY KNOX LIBRARY
NAVAL POSTGRADUATE SCHOOL
MONTEREY CA 93943-5001

REPORT DOCUMENTATION PAGE

Form Approved OMB Np. 0704

Public reporting burden for this collection of information is estimated to average 1 hour per response, including the time for reviewing instruction, searching existing data sources, gathering and maintaining the data needed, and completing and reviewing the collection of information. Send comments regarding this burden estimate or any other aspect of this collection of information, including suggestions for reducing this burden, to Washington headquarters Services, Directorate for Information Operations and Reports, 1215 Jefferson Davis Highway, Suite 1204, Arlington, VA 22202-4302, and to the Office of Management and Budget, Paperwork Reduction Project (0704-0188) Washington DC 20503.

1. AGENCY USE ONLY (Leave blank)	2. REPORT DATE Mar 24 1994	3. REPORT TYPE AND DATES COVERED Master's Thesis
----------------------------------	--------------------------------------	---

4. TITLE AND SUBTITLE A COMPUTER-ASSISTED FINAL EXAMINATION SCHEDULING SYSTEM FOR THE NAVAL POSTGRADUATE SCHOOL	5. FUNDING NUMBERS
--	--------------------

6. AUTHOR(S) Pedro F. Golmayo	
--------------------------------------	--

7. PERFORMING ORGANIZATION NAME(S) AND ADDRESS(ES) Naval Postgraduate School Monterey CA 93943-5000	8. PERFORMING ORGANIZATION REPORT NUMBER
---	--

9. SPONSORING/MONITORING AGENCY NAME(S) AND ADDRESS(ES)	10. SPONSORING/MONITORING AGENCY REPORT NUMBER
---	--

11. SUPPLEMENTARY NOTES **The views expressed in this thesis are those of the author and do not reflect the official policy or position of the Department of Defense or the U.S. Government.**

12a. DISTRIBUTION/AVAILABILITY STATEMENT Approved for public release; distribution is unlimited.	12b. DISTRIBUTION CODE A
--	------------------------------------

13. ABSTRACT *(maximum 200 words)*
 This thesis designs, develops and tests a computer-assisted system to construct final examination schedules at the Naval Postgraduate School. The system is based on a greedy heuristic that produces high quality solutions for 200 examinations in a few minutes on a personal computer. Comparisons between computer constructed schedules and the manual schedule for the 1994 winter quarter show the manual schedule's superiority. Despite this observation, the computer system's ability to rapidly produce feasible schedules (approximately 15 minutes compared to 5 days) makes it ideal to assist the schedulers and to conduct policy studies. One policy study conducted in this thesis shows a reduction in classrooms reserved solely for final exams has little impact on the quality of the schedule. Another policy study shows the difficulty of finding any schedule without some students having back-to-back examinations.

14. SUBJECT TERMS Examination scheduling, examination conflict, student clique.	15. NUMBER OF PAGES 93
--	-------------------------------

17. SECURITY CLASSIFICATION OF REPORT Unclassified	18. SECURITY CLASSIFICATION OF THIS PAGE Unclassified	19. SECURITY CLASSIFICATION OF ABSTRACT Unclassified
		20. LIMITATION OF ABSTRACT UL

Approved for public release; distribution is unlimited.

A Computer-assisted
Final Examination Scheduling System
for the Naval Postgraduate School

by

Pedro F. Golmayo
Lieutenant Commander, Spanish Navy

Submitted in partial fulfillment
of the requirements for the degree of

MASTER OF SCIENCE IN OPERATIONS RESEARCH

from the

NAVAL POSTGRADUATE SCHOOL
March 1994

Author:

Pedro F. Golmayo

Approved by:

Gordon H. Bradley, Thesis Advisor

Robert F. Dell, Second Reader

Peter Purdue, Chairman
Department of Operations Research

ABSTRACT

This thesis designs, develops and tests a computer-assisted system to construct final examination schedules at the Naval Postgraduate School. The system is based on a greedy heuristic that produces high quality solutions for 200 examinations in a few minutes on a personal computer. Comparisons between computer constructed schedules and the manual schedule for the 1994 winter quarter show the manual schedule's superiority. Despite this observation, the computer system's ability to rapidly produce feasible schedules (approximately 15 minutes compared to 5 days) makes it ideal to assist the schedulers and to conduct policy studies. One policy study conducted in this thesis shows a reduction in classrooms reserved solely for final exams has little impact on the quality of the schedule. Another policy study shows the difficulty of finding any schedule without some students having back-to-back examinations.

112
3
2
1

TABLE OF CONTENTS

I.	INTRODUCTION	1
A.	THE NAVAL POSTGRADUATE SCHOOL	1
B.	FINAL EXAMINATION SCHEDULING AT NPS	2
C.	GOALS FOR THE RESEARCH	4
	1. Shorten Time	4
	2. Improve Quality - Support Scheduler	5
	3. Policy Studies	6
D.	METHOD	6
E.	THESIS STRUCTURE	6
II.	PROBLEM DESCRIPTION	8
A.	THE NPS FINAL EXAMS SCHEDULING PROBLEM	8
B.	LITERATURE	8
C.	DIMENSIONS OF THE NPS PROBLEM	12
D.	SOME ARGUMENTS SUPPORTING THE SELECTION OF THE HEURISTIC APPROACH	12
E.	PREVIOUS DESCRIPTIONS OF THE PROBLEM.	13
F.	CONSTRAINTS	13
G.	DESIRABLE FEATURES	15
H.	EXCEPTIONS	16
III.	MEASURES OF EFFECTIVENESS	17

A.	MOE1. TIME OF EXECUTION	18
B.	MOE2. NUMBER OF SEATS NEVER USED	18
C.	MOE3. UNSCHEDULED COURSES.	19
D.	MOE4. ROOM ADEQUACY	19
E.	MOE5. EXAM TIME DISPERSION	20
F.	MOE6. NUMBER OF BACK-TO-BACK EXAMS	21
IV.	THE DATA	22
A.	CLASS SCHEDULE OUTPUT DOCUMENTS	22
B.	DATA AVAILABLE	22
C.	DESIGNATORS USED IN THE NPS SCHEDULING PROCESS	23
1.	Course Designator.	24
2.	Faculty Designator.	24
3.	Clique Designator.	24
4.	Room Designator.	24
D.	TRANSFORMATION OF THE INITIAL DATA	25
V.	AN HEURISTIC APPROACH	26
A.	THE HEURISTIC APPROACH	26
1.	A Partial Proof of Feasibility Concerning Course Conflicts.	27
2.	A Case of Infeasibility Due to Classroom Availability.	28
3.	A Measure of Course Scheduling Complexity.	28
4.	A Measure of Period Adequacy.	31
5.	A Measure of Classroom Adequacy.	32

6. The Heuristic	32
B. PROGRAM IMPLEMENTATION.	34
1. General Flow Chart.	34
2. Period Ranking Flow Chart.	35
3. Sets of Constraints.	35
4. Coefficients to Determine Complexity.	35
5. Course Scheduling Complexity Evaluation.	36
6. Rules to Assign Period Scores	37
7. Output Layout.	38
a. Course Assignment.	38
b. Courses not Scheduled.	39
c. MOEs.	39
VI. ANALYSIS OF MANUAL AND COMPUTER-ASSISTED SOLUTIONS	
WINTER QUARTER 1994.	40
A. INPUT DATA	40
B. MODIFICATIONS TO THE INITIAL DATA	41
C. MANUAL SOLUTION EVALUATION	41
1. Constraint Violations.	41
2. Time to Get a Solution.	42
3. MOEs.	42
4. Final Examination Distribution Across the Week.	42
D. COMPUTER-ASSISTED SOLUTION EVALUATION	43
1. Time to Get a Solution.	43
2. MOEs.	44

3. Final Examination Distribution Across the Week.	44
E. DIFFERENCES BETWEEN THE MANUAL AND COMPUTER-ASSISTED SOLUTIONS.	45
VII. POLICY STUDIES USING THE COMPUTER-ASSISTED METHOD.	47
A. TWO POLICY STUDIES	47
B. RESULTS WITH REDUCTION IN THE NUMBER OF ROOMS	47
1. No Rooms Available in Root Hall.	48
2. MOEs with no Rooms in Root Hall.	48
3. Distribution of Exams, Students and Rooms for Every Period.	49
4. MOEs with no Rooms on First Floor of Glasgow Hall.	49
5. Distribution of Exams, Students and Rooms for Every Period.	51
C. RESULTS OBTAINED CONVERTING DESIRABLE FEATURE D1 INTO A RIGID CONSTRAINT	51
1. MOEs with no Back-to-back Exams Permitted.	52
2. Distribution of Exams, Students and Rooms for Every Period.	53
VIII. CONCLUSIONS	55
A. ACHIEVEMENT OF THE GOALS	55
1. Shorten Time.	55
2. Improve Quality.	56

3. Policy Studies	56
B. POSSIBLE IMPROVEMENTS TO THE HEURISTIC	57
C. FUTURE POLICY STUDIES	57
1. Graduating Students	58
2. Courses not Holding a Final Examination	58
3. Impact of Final Examinations for all Courses	59
4. Impact of Refresher Courses	59
5. Impact of Delaying Final Examination Scheduling	59
6. Identify Quality Measures	60
7. Impact of Using Three Non-consecutive Periods a Day	60
8. Degree of Room Utilization	61
9. Impact of Using Additional Spaces	61
10. Impact of Non-simultaneity for all Segments of a Course.	62
11. Impact of Students with More Than Four Examinations	62
12. Effect of Different Periods each Day	62
13. Impact of Changes in the Number of Students.	63
APPENDIX A: GLOSSARY OF TERMS	64
APPENDIX B: ACADEMIC DEPARTMENT DESIGNATORS	68

APPENDIX C: FLOOR PREFERENCES BY DEPARTMENT	70
APPENDIX D: HIGH LEVEL FLOW CHART OF THE PROGRAM . . .	73
APPENDIX E: PERIOD RANKING FLOW CHART	74
APPENDIX F: PARTIAL SOLUTION OUTPUT	75
REFERENCES	76
INITIAL DISTRIBUTION LIST	78

LIST OF TABLES

5.1	COEFFICIENTS USED TO EVALUATE COURSE COMPLEXITY . .	37
6.1	MANUAL SOLUTION: NUMBER OF FINAL EXAMINATIONS, ROOMS USED AND STUDENTS EXAMINED FOR EACH PERIOD	43
6.2	COMPUTER-ASSISTED SOLUTION: NUMBER OF FINAL EXAMINATIONS, ROOMS USED AND STUDENTS EXAMINED FOR EACH PERIOD	45
7.1	COMPUTER-ASSISTED SOLUTION: NUMBER OF FINAL EXAMINATIONS, ROOMS USED AND STUDENTS EXAMINED FOR EACH PERIOD WITHOUT ROOT HALL 2nd FLOOR	49
7.2	COMPUTER-ASSISTED SOLUTION: NUMBER OF FINAL EXAMINATIONS, ROOMS USED AND STUDENTS EXAMINED FOR EACH PERIOD WITHOUT GLASGOW HALL 1ST FLOOR	51
7.3	COMPUTER-ASSISTED SOLUTION: NUMBER OF FINAL EXAMINATIONS, ROOMS USED AND STUDENTS EXAMINED FOR EACH PERIOD WITH NO BACK-TO-BACK EXAMS PERMITTED .	54

EXECUTIVE SUMMARY

The Naval Postgraduate School (NPS), in Monterey, California, offers courses during four separate quarters each year. Courses start and finish in a period of 12 weeks. The last week of the course is dedicated to final examinations.

The schedulers in the Registrar's Office are charged with the construction of a final examination schedule complying with several rigid constraints and, if possible, maximizing several desirable features. Currently the final examination schedule is constructed by the schedulers manually in an intense process that lasts one week. The schedule is constructed using rules of thumb developed during the last 25 years. This thesis designs, develops and tests a computer-assisted system to help the schedulers.

The problem of examination scheduling, or examination timetabling, is common to many educational institutions and has been studied previously by many authors. The solutions found in the open literature are designed for the specific problems of those institutions. A general definition of the problem that could be adapted to the peculiarities of the NPS is not available. Although the scheduling problem can be modeled as a mixed integer programming problem, solving the problem optimally is commonly considered untractable for the

dimensions found at the NPS. Therefore this thesis develops and solves the problem heuristically.

There are three main objectives for the system. First, to shorten the time the schedulers dedicate to final examination scheduling. Second, to provide a method to evaluate the quality of the schedules and therefore, improve them. Third, to provide a means to obtain, in a short time, high quality solutions which allow policy issues to be studied.

Two programs have been developed to meet the objectives. The first constructs examination schedules using a greedy heuristic algorithm and evaluates the solutions obtained. The second program calculates the same evaluation for schedules contained in an external file (the manual schedule).

The heuristic algorithm uses a set of coefficients to evaluate the scheduling complexity of every exam. Changes in the values of these coefficients modifies the scheduling complexity of every exam and therefore the solution. The system implemented includes five different sets of coefficients to evaluate the complexity. The user can change these coefficients. The MOE's permit the user to pick the best solution. The number five has been chosen arbitrarily based on an acceptable time of execution, increased probability of getting a good solution and to provide good solutions over different quarters.

The program was executed using the Winter 1994 Quarter data and the best computer schedule and the manual schedule

are compared. As expected the quality of the automatic solution is not as high as that of the manual solution, but not so low as to consider it invalid. The computer schedule is considered to be of high enough quality that the schedulers could use it as a starting point. In an emergency situation the computer schedule could be adapted by NPS.

Two sample policy studies were conducted to demonstrate this use of the computer system. The first studies the impact of a reduction in the number of classrooms available for examinations. For a reduction of 11 classrooms of several sizes (all first floor of Glasgow Hall) a schedule is obtained containing all courses and with only a small loss of quality in the solution. The policy study investigated the impact of not permitting back-to-back examinations for the students. The system could not find any schedule that did not have back-to-back examinations for at least some students. The best schedule in this case is unable to schedule six examinations.

The conclusions obtained from this study are that it is possible to help the schedulers and probably to shorten the time required for final examinations scheduling by providing them with a computer-assisted initial solution. The Measures of Effectiveness can be applied to any solution by means of the stand-alone program and can be used to compare different solutions. Finally the quality of the schedules provided by the computer-assisted method will support a variety of policy studies.

ACKNOWLEDGMENT

I wish to express my gratitude to course scheduler Mrs. Edith Phillips for her support and cooperation. She made understandable the difficulties of the final exams scheduling problem and was always available to answer any question.

I extend my appreciation to Senior Programming Analyst Lloyd Nolan for his support providing the data needed.

I. INTRODUCTION

A. THE NAVAL POSTGRADUATE SCHOOL

The Naval Postgraduate School (NPS) at Monterey, California, is an academic institution dedicated to increasing the combat effectiveness of the United States Navy and Marine Corps by providing post-baccalaureate degree and nondegree programs in a variety of subspecialty areas not available through other educational institutions [Ref.1].

There are 11 Academic Departments and four interdisciplinary academic Groups offering a total of 37 programs to approximately 1800 students. Most of the students pursue one of the several Master degrees, some are pursuing a dual Master and some others are involved in a PhD program. The duration of the Master programs varies between one and two and a half years. Most of the curricula begin every six months. This means that in a curriculum such as Operations Analysis, which last 2 years, at any time there are 4 sections of students in different stages of their studies.

The academic calendar at NPS is structured into four three month quarters. Final examinations are required for all courses during the final week of each quarter (Monday through Thursday). The Registrar's office is charged with producing

a course schedule for lectures and a final examination schedule which takes into account academic and student needs.

B. FINAL EXAMINATION SCHEDULING AT NPS

The course schedule and the final examination schedule must be such that every student can take the courses they request. There are a few exceptions to this which are negotiated on a case by case basis between the schedulers and the pertinent Curricular Officer.

The problem, in its basic form, consists of assigning the set of examinations to a set of available periods and classrooms, so that no student has more than one examination in the same period. This problem is not difficult when all students, in the same stage of their curriculum, are enrolled in the same set of courses. However, as their studies progress, NPS students have increasing opportunities to take elective courses in their own or in other academic departments.

The basic problem outlined above becomes even more complex when some rigid constraints are added, such as classroom availability, time available, maximum daily number of exams per student, and maximum daily number of exams per professor. These are only some constraints from a complete list given in Section II.F. Other desirable characteristics of the schedule are considered as additional lower priority constraints and are listed in Section II.G.

Currently the final examination timetable is produced manually in a process that takes one week and requires the complete dedication of very experienced personnel. This manual process produces only one solution to the problem. The final examination scheduling is one of the final steps in the two month process of course and final examination scheduling.

The scheduling process is structured in several steps. First it is necessary to forecast the courses to be taught and consequently needs for faculty and rooms. This forecasting step is carried out up to a year in advance of the quarter of interest. Second, an iterative pre-scheduling process is carried out to clearly determine which courses are to be offered in the quarter, what students are going to take them and what faculty members are going to teach them. This step is carried out at the beginning of the quarter previous to that being scheduled. With the information from the previous step and a knowledge of available rooms, the next step assigns periods and rooms for each course. This process, which lasts six or seven weeks, is carried out by very experienced personnel using manual methods and rules of thumb developed during the last twenty five years. Finally, once the class schedule is done, it is necessary to construct the final examinations schedule to be executed during the twelfth week of the quarter.

C. GOALS FOR THE RESEARCH

The present manual scheduling process frequently requires the schedulers to work overtime, this situation may worsen if the number of students in the School increases, there are fewer rooms available, or the number of curricula increases. Also if one of the schedulers is not available, the workload for the others becomes insurmountable. In this situation it is very difficult to spend time investigating alternatives not aimed to solve the immediate problem.

This thesis develops a computer-assisted scheduling program to produce final exam timetables. The goals of this research are:

1. Shorten Time

While it is possible to shorten the time needed to produce the final examination schedule, this is only a small part of the total time needed. This goal is therefore qualified by the following observations:

- The time taken currently by this process is approximately 10 person days. Even when time could be saved in the actual process of scheduling the final examinations, collateral work of preparing and entering input data could not be reduced very much. Any computer solution also requires detailed inspection.
- The early date in the previous quarter at which no changes in course registration are permitted, causes numerous registration changes in the first two weeks of every quarter. This fact limits the value of the solution obtained. If the time to produce the final examination schedule is shortened, more time could be available for the students to choose their next quarter courses and hopefully fewer changes in registration would occur during

the first two weeks of a quarter and therefore the final examinations schedule would be more valid.

- Providing the students with more time to decide their next quarter enrollment has a limit given by the time necessary for the Bookstore to get the books necessary for the next quarter.
- Courses and final examinations can't be scheduled simultaneously since it is desired to assign the final examination for a course to the same room used for lectures, whenever possible. Therefore final examination scheduling cannot be attempted until the course schedule is finished.

2. Improve Quality - Support Scheduler

It is doubtful that any computer-assisted scheduling program can yield a better schedule than those generated by the schedulers. This is true since it is almost impossible for a program to capture every single factor taken into account by two experienced schedulers.

The computer-assisted process developed in this thesis can provide the schedulers with some information which could help them in their search for a solution. First, if the computer can reach a feasible solution they can, at least, get the same and hopefully improve it. Second, the computer-assisted solution can provide the scheduler with data about room utilization, number of course conflicts, etc. Third, the computer-assisted solution provides a method for evaluating the quality of different manual or automatic solutions.

3. Policy Studies

If the computer-assisted method provides reasonably acceptable solutions, even when not as good as the solution provided by the manual process, it would be possible to perform tests of how the solution is affected by several policy variables, like time available, the number of rooms available, the number of courses requiring final examination, etc. The provision of several measures of effectiveness would permit these studies.

D. METHOD

The steps performed in this thesis to arrive to a solution are the following:

- Clearly define the objective and secondary goals of the computer-assisted solution, including the constraints of the problem and desired features.
- Build an electronic data base of course calls and faculty assignments.
- Develop a data base of courses, rooms and faculty.
- Develop Measures of Effectiveness (MOE) for various aspects of the schedule.
- Develop a weight-driven exam scheduling heuristic to quickly produce schedules and evaluate MOEs.
- Perform studies of various policy options.

E. THESIS STRUCTURE

This thesis is structured in the following way:

- Chapter I presents an introduction to the problem of final examination scheduling in the NPS.

- Chapter II references previous studies at NPS and similar problems in other institutions. This chapter also defines NPS's goals, constraints and other desirable features.
- Chapter III defines Measures of Effectiveness (MOE) to evaluate solution quality.
- Chapter IV defines the data used to get the final exam schedule.
- Chapter V describes the heuristic method used in the computer algorithm.
- Chapter VI analyzes the results obtained by the manual method and the computer-assisted method.
- Chapter VII explores two policy studies.
- Chapter VIII presents the conclusions and recommendations.
- Appendix A presents a Glossary of the terms used in the thesis.
- Appendix B presents the designators of each academic department.
- Appendix C presents the floor preferences for each academic department.
- Appendix D is a high level flow chart of the program to construct the schedule.
- Appendix E is a flow chart of the algorithm used to rank periods.
- Appendix F presents a sample of the solution output.

II. PROBLEM DESCRIPTION

A. THE NPS FINAL EXAMS SCHEDULING PROBLEM

At NPS there have been at least two previous attempts to solve the final examinations scheduling problem by computer-assisted methods. In 1966 HAMS [Ref.3], the Heuristic Academic Master Scheduler was created. This program didn't succeed due to its inability to get a feasible solution for all the exams.

In 1985 there was another attempt by Fiegas [Ref.4]. It proposes an heuristic algorithm in which exams are assigned to periods without any special pre-arrangement. If there are exams that could not be allocated to any period, (called blocked exams) a new arrangement is made in the order the exams are processed by the algorithm, this procedure is then repeated using some rules until a feasible solution is obtained or the number of iterations exceeds a pre-established limit.

B. LITERATURE

In the open literature several approaches have been made to the examination scheduling. Broder [Ref.5] proposes a method to yield a minimal number of student conflicts in scheduling final examinations. The goal is achieved by iteratively evaluating a nonlinear set of equations. The process implements a random selection of assignments. This

heuristic can find many solutions that are not necessarily optimum, but are locally minimal. No effort is made to improve the solution obtained.

The other possible approaches to this problem would be to define and solve an integer linear programming model. The literature about this topic abounds with evidence that this type of problem becomes untractable as soon as the number of course, room and time constraints grows above some limits. Those limits are certainly exceeded by the NPS problem.

A similar problem is studied by Eglese et al. [Ref.10]. Their study produces a timetable for seminars offered in a week (four days) conference. The number of different seminars to schedule are 15, they can be repeated any number of times, though with some constraints about maximum and minimum number of participants. There are constraints imposed by the number of rooms available (seven), the requirement of some seminar leaders for blackout facilities in the rooms assigned to them (only 5), and the fact that one seminar leader was responsible for two of the seminars. The number of participants is 265, each one makes an advance request for the four seminars in which he desires to participate. This problem, evidently smaller than that of scheduling the final examinations at the NPS, is formulated by the authors as a mixed integer linear-programming problem. The formulation requires over 15,000 variables, including 60 binary variables.

David Johnson [Ref.11] present a study of the final exams scheduling problem at the University of South Pacific (Fiji).

The dimensions of the problem are the following:

- 10 exam days with two sessions each one, making a total of 20 sessions.
- 2350 students.
- 200 examinations have to be scheduled at the end of each semester.

The constraints of the problem are the following:

- The timetable must avoid all student conflicts.
- All examinations should be completed in at most 2 weeks (20 sessions).
- It must be possible to accomodate all candidates in the various examination rooms available.
- Those examinations with a larger number of candidates should come earlier in the examination period to allow the maximum time for marking.
- Where a student is taking more than one examination, these should be spread out throughout the 2 weeks if at all possible so that there is some time for preparation before each examination.

For the previous problem an integer linear programming model is formulated, with the objective function of minimizing the overall number of consecutive examinations. The formulation presented doesn't take into account several constraints imposed in the NPS problem. For the formulation presented a problem involving 100 examinations extended over 20 sessions and requiring one room for each exam would lead to

287,240 constraints in 96,050 binary variables. The author concludes that even after improving the formulation of the integer programming model, it would not be practical to solve the model.

Carter [Ref.12] identifies the problem of finding a conflict free timetable with the vertex coloring problem, which is known to be NP-complete. His conclusions states:

When the problem is expressed mathematically, the numbers of variables and constraints become unmanageably large for practical size problems.

Later, Carter et al.[Ref.13] study the classroom assignment problem. The final examination problem matches the definition of **interval classroom assignment** problem presented by these authors. They show the feasibility test to be polynomially solvable in $O(n)$ time and the problem of finding a solution (not optimal) to be NP-complete and therefore assumed unsolvable.

Most of the approaches to the final examinations scheduling problem reject an integer linear programming method because its complexity. Instead, the common approach is by means of an heuristic algorithm.

The approach adopted in this thesis is to develop a heuristic algorithm that constructs a solution with reasonable quality (a good solution) in a reasonable computing time.

C. DIMENSIONS OF THE NPS PROBLEM

The dimensions of the NPS problem for the 1994 Winter Quarter are indicated below. The dimensions are similar for other quarters.

- Number of students = 1778
- Number of classrooms = 74
- Number of periods = 16
- Number of professor-exams = 216 (professor-exam is defined in Appendix A)
- Average number of conflicts for each course = 7.7
- Maximum number of conflicts for a course = 81
- Minimum number of conflicts for a course = 1

D. SOME ARGUMENTS SUPPORTING THE SELECTION OF THE HEURISTIC APPROACH

The considerations discussed in the preceding section led the author of this thesis to choose the approach of developing an heuristic algorithm as a way of obtaining a good, although not necessarily optimal, solution for the scheduling problem. Other arguments supporting this approach are the following:

- Some of the constraints expressed in Chapter II Sections F and G, such as room preferences, are very difficult to model in an integer linear programming model but are easily applied in an heuristic model.
- The heuristic approach follows what is being done by hand to obtain a solution. This allows the program to use heuristics that have matured and improved over more than 20 years of accumulated experience.

- If there are changes in the future, it may be easier to add or change constraints in the heuristic algorithm than in an integer linear programming definition.
- The heuristic program runs in a personal computer in a predictable time. An integer problem of this dimension, if it were feasible to solve, probably could not be run quickly on a personal computer.

E. PREVIOUS DESCRIPTIONS OF THE PROBLEM.

The problem at NPS has been studied by Nolan and Youngblood [Ref.2].

Like scheduling courses for the regular instruction period, scheduling final exams involves selecting time periods and rooms. Unlike scheduling for the regular instruction period, however, only one two-hour time period is required for each course, regardless of the number of segments or credit hours, and frequently more than one room is required to accommodate the students in all segments.

The authors make an exhaustive description of the final examination schedule problem, the constraints and "unwritten rules" of the process and a step by step description of the manual process. The salient features of their description and conversations with the course-schedulers follow.

F. CONSTRAINTS

The following constraints should be taken into account when scheduling final exams [Ref.6], [Ref.7], [Ref.8]:

- C1.- The timetable must avoid both student and professor conflicts. No student or professor should have more than one examination at the same time.

- C2.- The timeframe available for final examinations is four days, Monday through Thursday of the 12th week of a quarter
- C3.- The hours available for final examinations in a day are from 0800 to 1700.
- C4.- All courses that require final exam should be given a two hour period for this purpose.
- C5.- A student can have at most 2 exams per day.
- C6.- The room or set of rooms used for an exam has to have a capacity of 150% of the number of students that are going to take the exam.
- C7.- All segments of a same course should have the exam at the same time, even when they have different professors.
- C8.- When there is not a single room available to hold all the students of a professor-exam, the rooms assigned to a professor have to be in the same floor of the same building and as close as possible. No professor-exam should be assigned to more than three rooms.
- C9.- There is no limit on the number of exams a faculty member can attend in a day, but they cannot be scheduled for back-to-back exams. It is mandatory to have at least one hour between exams.
- C10.- Faculty members cannot be scheduled to attend two different exams at the same time.
- C11.- On request, some exams are preassigned a period and room.
- C12.- A room that has a final exam scheduled must not be scheduled for any other event in the hour following the exam. That is, no other exam or refresher class can be scheduled to begin immediately after the exam.
- C13.- Graduating students should not be scheduled for exams on Thursday morning, since this is the time for the graduation ceremony.
- C14.- Each professor teaching a course has to be assigned a classroom or set of classrooms for all his students apart from the classrooms assigned to other professors teaching the same course.

- C15.- Some courses have two professors for the same group of students. In this case both professors should be available at the time their final examination is scheduled.

G. DESIRABLE FEATURES

There some desirable characteristics of the Final Exam Schedule that have not been specifically expressed, but after many years of manual scheduling have been accepted as additional lower priority constraints [Ref.6], [Ref.7], [Ref.8]. These are:

- D1.- It is permitted but not desirable that students have two exams back-to-back.
- D2.- No requirement is established in relation to what hours to use from the 9 hours daily timeframe, but continuing with the current use by the schedulers, the periods to consider will be 0800-1000, 1000-1200, 1300-1500, 1500-1700.
- D3.- If it is possible it is desirable that final exams take place in the same room in which the corresponding lectures take place.
- D4.- It is desirable that exams take place in the building where the department's office is located.
- D5.- In the case an exam cannot be held in its own department building, every department has some preferences about alternative buildings. These are expressed in Appendix C.
- D6.- It is desirable for graduating students not to have exams on Thursday afternoon.
- D7.- It is desirable that courses of level 1000 and 2000 be scheduled after Tuesday.
- D8.- Constraint C6 defines a minimum room capacity for examinations but no maximum. It is desirable to provide students with as much room as possible.

This thesis initially implements desirable feature D2 as a constraint. When solutions are not found, this constraint is relaxed to allow for examinations to be scheduled on Friday morning. All other desirable features, except D8 are taken into account to compute the measures of effectiveness of the solutions obtained. Some desirable features pose contradictory goals. For example, an examination period could be good in terms of examination time distribution across the week and bad in terms of classrooms available; the opposite could happen in another period.

H. EXCEPTIONS

In case a schedule can not be found with the constraints in Section II.F the following exceptions can be made:

- E1.- Exams can be scheduled Friday morning from 0800 to 1200.
- E2.- Examinations with preassigned room can be scheduled in another room if that preassigned room is not available.

III. MEASURES OF EFFECTIVENESS

In order to assess the value of the solutions proposed as an alternative to the system currently in use and in order to conduct the policy studies cited in Section I.C, we need to establish some consistent, quantitative, measurable and credible metrics of how well the new and the old system achieve the goals.

In regard to the first goal expressed in Section I.C, **Shorten time**, the time of execution is considered as a MOE to be compared with the time required by the current process of manual scheduling. Additional time required to prepare data or to write and distribute final documents is not considered.

In regard to the second goal, **Improve quality**, the measures of effectiveness (MOE's) have to take into consideration the interests of the several groups involved in the problem. These are: The School administration (here represented by the departments), the School faculty and the students. Each of these groups have independent interests concerning the schedule of final examinations. The factors that make a solution satisfactory or not for these groups are:

- time each examination is scheduled.
- location (building and room) where the exam takes place.

- distribution of the examinations across the four days.
- number of rooms for a given exam.

The Administration is also concerned about the percentage of exams included in the solution.

In regard to the third goal **Conduct policy studies**, time is the most important factor to permit the study of new policies, provided the schedules are of high quality.

All the MOEs can be computed with the input data and the solution. A stand-alone program is provided to evaluate the manually produced schedule with the same MOEs. The design of the computer program to compute the MOEs makes it possible to change the weights on the MOE calculations and also add additional measures of quality.

A. MOE1. TIME OF EXECUTION

The MOE1 expresses the time required to solve the scheduling problem. MOE1 includes the time needed to produce a given number of schedules using the computer-assisted method.

B. MOE2. NUMBER OF SEATS NEVER USED

From the Administration point of view it is important to minimize the number of different rooms used for the examinations, (how many times a room is used is of no concern). The Administration appears to have no preference on

the way the exams are distributed along the week, nor about the particular period in which an exam is scheduled.

MOE2 is defined as the total number of seats never used during the final examinations week and thus available to the Administration for other activities. In regard to room use saving, it is not the same to use a small room as to use a large room. But it is not known what is more desirable for the Administration, to save a large room or to save several rooms with the same total number of seats as the large one. For large group activities the Administration would prefer the large room to be saved, but for several small group activities the alternative is better. Since no information about this preference is available, it is assumed that what matters is the total number of seats available for the Administration during all the final examinations week. The larger the number of seats never used the better the solution obtained.

C. MOE3. UNSCHEDULED COURSES.

MOE3 is defined as the sum of the number of students for all the exams not included in the schedule.

D. MOE4. ROOM ADEQUACY

Faculty seems to be primarily concerned about all exams being scheduled in the timeframe defined in the constraints, without resorting to extra periods. Faculty and students also have a preference for the location assigned to the

examinations. It is desirable that examinations be scheduled in the same room in which the lectures have taken place whenever possible. If not possible, the next preference is to have rooms assigned in the same building in which the lectures have taken place. If neither is possible, it is assumed that the next preference is to have room(s) assigned in the department building, when this is not the building where the lecture takes place. Finally, there are some preferred buildings because of the proximity to the department building.

MOE4 is defined as the sum of the number of students of each exam weighted by a factor determined by the location in which the exam takes place.

E. MOE5. EXAM TIME DISPERSION

Students, in general, are concerned about the spread across the week of their exams. Normally it is preferred to have the exams as spread-out as possible across the week. Even though it is permitted for a student to have two exams in the same day, it is preferred that this circumstance affect the minimum number of students. Even though back-to-back exams are permitted for students this is highly undesirable.

Even though permitted, it is also desired that graduating students have no exams to take on Wednesday afternoon or on Thursday afternoon. Constraint C13 prohibits scheduling examinations for graduating students on Thursday morning.

MOE5 is determined by assigning a score to every student's individual schedule using the following rules:

- If the student never has two exams in a day, or having two exams one day, the previous day had no exam, assign 5 points to this individual schedule.
- If the student has two exams only one day, preceded by a day with one exam, assign 4 points to the individual schedule.
- If the student has two non-consecutive days with two exams, assign 3 points to the individual schedule.
- If the student has two consecutive days with two exams, assign 2 points to the individual schedule.
- Subtract one point from the previous score for each time two back-to-back examinations have been scheduled.

The higher the value obtained the better is the solution in regard to this MOE. The assignment of examinations to graduating students on Thursday afternoon is penalized when the periods ranking is made. However, no MOE takes into account how many graduating students are scheduled examinations for periods on Thursday afternoon.

F. MOE6. NUMBER OF BACK-TO-BACK EXAMS

This MOE expresses the number of students who have back-to-back exams in the schedule. A student having back-to-back exams two times increases this MOE by two.

IV. THE DATA

A. CLASS SCHEDULE OUTPUT DOCUMENTS

Once the process of class scheduling for the next quarter has been finished, the scheduling of final exams begins. At this time the following documents are available:

- Student Schedule Cards.
- Instructor Schedule Cards.
- Regular classroom and laboratory Schedule Cards.
- Master Instruction Schedule (except the information concerning Final Exams).

A description of these documents is made in the Glossary of terms in Appendix A.

B. DATA AVAILABLE

The input data for the examination scheduling problem is, in part, contained in the School mainframe computer. Unfortunately, some data is not in the mainframe and has to be introduced manually [Ref.9]. As described in Chapter VI Section A, the data in the School database is manually augmented to construct data files on the mainframe.

The data obtained from the data files in the mainframe is entered into the program by input files that contain:

- Names of the courses requiring final examination.

- Names of the faculty teaching every segment of any course. If there are two or more professors in a same segment of a course, this is also known.
- Number of students assigned to every professor in each segment of any course.
- Code for the student cliques taking any course, and number of students in the clique.
- Lecture room used during the class period.
- For each course a list of conflicting courses.

The following information not in the mainframe is also used by the program:

- Rooms available for the final examinations, including any period in which any room is not available.
- Unavailability of any professor at any period. This data is entered manually at execution time.
- Special requirements of room or scheduling time for any exam. This data is entered manually at execution time.
- Preferred buildings to conduct final examinations for every department. This data is included in the code.
- Existence or not of graduating students in any course. This data is contained in a file read by the program.

C. DESIGNATORS USED IN THE NPS SCHEDULING PROCESS

The program uses the same designators for the several types of data as those used by the schedulers, with only a minor modification concerning room identification.

1. Course Designator.

An alpha-numeric symbol consisting of two letters and four numbers designates each course. The first two letters designate the academic department which offers the course. Appendix C contains the academic department designators.

2. Faculty Designator.

Professors are designated by a symbol formed by two letters, a slash and two letters. The first two letters correspond to the academic department to which the professor belongs. The second pair is obtained from the professor's last name to identify the professor in the department.

3. Clique Designator.

A clique designator is composed of two letters and three or four digits. The two first letters and two first numbers identify the section in the curriculum to which the clique belongs. The last digits (one or two) identify the clique in the section.

4. Room Designator.

A room designator is composed of a letter indicating the building where the classroom is placed, one alpha-numeric character indicating the floor in the building in which the room is placed and two more digits identifying the particular room in that floor. In very few occasions a fifth alphabetic character is added to distinguish between two connected rooms. In the program implementation this fifth character has been

supressed and whenever necessary the room identification has been given a new numerical identification composed of a letter and three digits.

D. TRANSFORMATION OF THE INITIAL DATA

The process of class scheduling takes place before the exam scheduling. The output data of the class scheduling phase is part of the input data for the exam scheduling problem. However the exam scheduling problem is solved with structures that are thought to be the best for this problem, not the structures available at the end of the class scheduling phase. The program developed is intended to be run in any personal computer not necessarily connected to the mainframe, therefore the data should be entered by diskette. An interface program, not contained in this thesis, reads the data from the mainframe and writes it to the diskette in the appropriate format to be read by the program of final examinations scheduling. This approach has the benefit that later modifications of the data structures generated by the class scheduling program will only require modifications in the interface program.

V. AN HEURISTIC APPROACH

A. THE HEURISTIC APPROACH

Before the search for a solution to the final exams schedule begins, it is convenient to check the feasibility of the problem defined. No procedure is available to test if all examinations can be scheduled. But, there are several cases of easily detected infeasibility such that a significant amount of time will be saved if they are detected before trying to look for a solution. If infeasibility is detected, the program will warn the user about this eventuality and will continue looking for a solution using the EXCEPTIONS permitted in Section II.H.

A graph can be made in which the nodes are the exams necessary to schedule. When an exam has a student clique in common with another exam, an arc links both nodes indicating a conflict in case of simultaneous scheduling. Similarly, if a faculty member teaches two courses there is an arc linking the corresponding nodes.

It is possible that the conflict graph can be decomposed in two or more independent unconnected components. This does not mean, however, that every component can be solved as if it were an independent problem. This is because even when components of courses can be separated, this only happens with

respect to student cliques and faculty conflicts. However, all examinations must use the same set of rooms. Thus, the final exam scheduling of all courses is interrelated and has to be considered as a whole.

1. A Partial Proof of Feasibility Concerning Course Conflicts.

During the final examination week, sixteen different periods are available. A proof of feasibility in regard to student and faculty conflicts consists of applying a vertex coloring algorithm to the conflict graph. Since a graph coloring is NP-complete, there are no efficient exact algorithms for problems of the scale of the NPS problem. Therefore an heuristic algorithm would have to be used. If a vertex coloring algorithm can color the conflict graph with 16 or fewer colors, the scheduling problem is feasible with respect to conflicting courses. The contrary is not true, that is, since the coloring graph algorithm is an heuristic and not an exact method, it could be the case that the coloring algorithm is unable to color the graph with 16 or fewer colors when this is really possible.

Thus the success of the coloring algorithm indicates the feasibility of the scheduling problem. The number of colors needed gives some indication of the inherent difficulty of the problem.

2. A Case of Infeasibility Due to Classroom Availability.

Every day, four different periods are available to schedule exams. However the constraint C11 doesn't permit a classroom to be used without at least an hour interval from exam to exam. This means that every classroom is available at most one period in the morning and one in the afternoon. That is, a classroom can be used, at most, eight times during the whole week. Multiplying the maximum number of classrooms available times 8 periods, gives the total number of classroom-periods available. After deducting from the number obtained the classrooms-periods not available for any reason, at least one classroom has to be assigned to every professor-exam. Therefore if the number of professor-exams is larger than the remaining number of classrooms available, the problem has no solution.

3. A Measure of Course Scheduling Complexity.

The heuristic used to solve the scheduling problem first assigns those exams that for several reasons are deemed to be complex to schedule. This complexity is evaluated by several factors affecting the exam. The reason the heuristic uses this approach is to facilitate the scheduling of these complex exams (in the scheduling sense) when the constraints of time and classroom have not yet being worsened due to the assignment of other exams. Therefore it is necessary to sort the courses by their complexity.

The complexity to schedule an exam is a figure that expresses how difficult an exam is to be scheduled taking into consideration those factors deemed to be significant. Those include:

- Number of professors teaching the course.
- Number of students enrolled in the course.
- Number of remaining conflicting courses.
- Proportion of courses already scheduled in the course curriculum.
- Number of possible periods remaining for the course.
- Whether the course has a period preassignment.
- Whether the course has some early or late schedule preference.
- Whether the course has room preassignment.
- Relation of number of remaining conflicts to number of students.

The formula used to compute the complexity number uses several sets of coefficients, associated with the factors mentioned above. The complexity number ranks, by relative grade of difficulty, the exams remaining to be scheduled.

One of the factors to determine the complexity number of an exam is the number of remaining courses with which the course conflicts. Therefore, once a course has been scheduled, the number of conflicts with some of the remaining unscheduled courses changes. The complexity numbers are recomputed every time an exam has been scheduled to update the order.

Care is taken so that a curriculum does not have all its courses scheduled at the beginning of the week and another has all its exams scheduled at the end of the week. To avoid this the complexity evaluation of a course takes into account the percentage of courses in the curriculum not yet scheduled. The bigger this percentage the greater is considered the complexity of the course; this tries to avoid great inequities from one curriculum to another.

Courses belonging to the first four quarters of any curriculum, when students have compulsory courses and rarely any electives, do not have much complexity due to conflicts nor to the presence of graduating students. However, they typically have a large number of students and more than one professor making them appear more complex than they really are. For this reason and to comply with desired feature D7 a decrement of complexity is applied to these courses.

When computing the complexity of a course, the number of feasible periods for this course are taken into account. The number of conflicts remaining, by itself, does not give a full indication of how difficult it is going to be to find a period for the course unless it is related with the number of possible periods.

When a course has been preassigned in time, or has a forbidden period at which can not be scheduled, its complexity is increased to force an early processing to find rooms available at the preassigned or permitted time.

The preassignment of room is not given additional complexity.

4. A Measure of Period Adequacy.

Once one exam has been selected to be scheduled because of its complexity, it is determined which is the best possible period for it. The process is executed for every professor-exam in the course. Every period is considered to evaluate student and faculty availability and if those conditions are met, a room or set of classrooms is preselected, if possible. If all the previous conditions are met, the period is assigned a score depending on the location of the set of classrooms selected, and if the set is composed of one or more classrooms, thus fragmenting the group of students. This factor has to take into account the several professor-exams involved, since one professor could be given a very high score set of classrooms and another a very poor one. The best case happens when a professor is assigned as exam classroom the lecture classroom he used during the regular course. The process also takes into account the preference of some buildings versus others. To evaluate the period it is also necessary to consider the number of students that are going to have back-to-back exams in case the period is definitely chosen. How early or late the period is in the week is also evaluated in order to penalize the late periods for the exams of highest priority. This is the reason, as will

be seen later, for a lack of uniformity in the distribution of exams across the week.

5. A Measure of Classroom Adequacy.

In order to meet desirable features D3, D4 and D5, the algorithm ranks possible sets of classrooms taking into account the following factors:

- Classroom is the lecture classroom.
- Set of rooms are located in the same building the lecture took place.
- Set of rooms is in the department building.
- Set of rooms is in some preferred building.
- Number of rooms in the set of rooms selected.

6. The Heuristic

This thesis develops a Greedy heuristic to solve the problem. The algorithm presented is greedy and sequential in the sense that the courses are scheduled one at a time. A course processed and scheduled is never processed again.

The heuristic determines the scheduling complexity of the exams. Once this has been done, the most complex exam is selected to be scheduled in the most convenient period available. To do this another ranking has to be made about the adequacy of every period for the selected course. The algorithm rejects all impossible periods and assigns a score to those possible, giving the highest score to the most convenient period and the lowest to the least convenient.

After this, the selected exam is assigned to the period with highest score and it is assigned classroom(s). Every time an exam is processed, a new evaluation of complexity is made for the exams remaining to be scheduled. This procedure continues until all exams have been processed. When no valid period is found for an exam, it is inserted in a list of unscheduled exams. The solution obtained is printed or send to a file.

The weights used to evaluate the scheduling complexity of a course, together with the weights given to rank the periods, determine the schedule obtained. If multiple sets of complexity coefficients are used, multiple schedules can be obtained. The MOE's permit the user to choose the best schedule. There is no reason to think that the best set of coefficients for a given problem is going to be the best for a different problem. For some problems it may be difficult to construct a solution that includes all the courses. Using several sets of coefficients increases the probability of obtaining a good schedule, if one exists. Hopefully, after adjusting the coefficients for several different problems (several quarters), good sets of coefficients will be identified.

How many sets of coefficients to use is an arbitrary decision based on the time of execution and the practicality of identifying many substantially different sets of coefficients (not just fine adjustments). The present implementation contains five sets of complexity coefficients,

which takes about 15 minutes on a personal computer. The user can modify the code very easily to include more sets of coefficients, but this increases the execution time and may not lead to better solutions.

B. PROGRAM IMPLEMENTATION.

The program has been implemented in Turbo-Pascal. There are two programs implemented, the first one finds the solutions for the final examination problem. This program permits the user to enter some initial conditions such as:

- Excluded days for any examination.
- Preassigned period for any examination.
- Preassigned room for any examination.
- Non-availability of any room at any period.
- Non-availability of any professor at any period.

A stand-alone program has been developed that reads a previous solution in a given format and evaluates the corresponding MOEs. This permits comparison of solutions obtained by the manual process with those obtained by the heuristic computer program.

1. General Flow Chart.

Appendix D shows the highest level flow chart of the final examination scheduling program.

2. Period Ranking Flow Chart.

Appendix E shows the flow chart of the period ranking process.

3. Sets of Constraints.

Initially the constraints implemented in the program are those expressed in Section II.F and Section II.G. However, it is possible to relax the constraint of 16 periods to 18 periods and to relax the preassignment of rooms (Exceptions E1 and E2). Both constraints are modified at the same time.

4. Coefficients to Determine Complexity.

There are sets of coefficients that permit the user to vary the weight assigned to each factor affecting the difficulty of scheduling a course, like the number of students, the number of conflicts of this course with other courses, special requirements, etc.

The program performs 5 iterations using 5 different sets of coefficients in order to find a feasible solution. If no solution is found after using the 5 available sets of coefficients, the set of constraints in force is modified and 5 new iterations are made using every set of coefficients.

Through the selection of these coefficients and those of period evaluation the performance of the program is modified. The task of finding good sets of coefficients requires running the program with many different sets of coefficients and then analyzing the results obtained. Since

the solution obtained does not have a linear relationship with the variables, a very small variation in a set of coefficients can result in totally different solutions or even not produce any solution. Intuition is of limited value when modifying the coefficients.

5. Course Scheduling Complexity Evaluation.

The formula used to evaluate complexity is the following:

A * Number of professors +
B * Number of students +
C * Number of remaining conflicts +
D * % of yet unscheduled exams in the curriculum +
E * Number of infeasible periods +
F * (remaining conflicts/possible periods)+
G * (remaining conflicts/number of students)+
H (if exam has a preassigned period) +

I (if exam contains graduating students) +
J (if course level 1000 or 2000).

The different sets of complexity coefficients used by the present implementation are shown in Table 5.1. These coefficients have been found by a trial and error process.

TABLE 5.1 COEFFICIENTS USED TO EVALUATE COURSE COMPLEXITY

COEFF	1st SET	2nd SET	3rd SET	4th SET	5th SET
A	50	50	50	50	50
B	20	20	20	20	20
C	200	300	80	1	200
D	2	2	2	2	2
E	1	1	1	1	1
F	100	1	0	50	200
G	100	300	300	600	10
H	250	450	250	250	250
I	400	0	400	400	400
J	-200	-300	-200	-200	-200

As can be seen, the coefficients D and E have little impact in the present implementation, but provision is made for future modifications.

6. Rules to Assign Period Scores

The routine to construct scores for the feasible periods, modify the period score in the following manner:

- All period scores are initialized to zero.
- If the period is a preassigned period for that examination, the score is the maximum integer possible in the computer.

- If the course has a preassigned classroom which is available in the period, the period score is the maximum integer possible in the computer decreased by 100 times the number of the period being evaluated. In this way priority is given to the earlier periods.
- If the room found is the lecture room for course lectures, the score is increased by 20.
- If the room is in one of the three most preferred floors the score is increased by 3.
- If the room is in one of the three next most preferred buildings the score is increased by 2.
- If the set of rooms found is composed of a single room, the score of the period is increased by 20.
- If the set of rooms is composed of two rooms, the score of the period is increased by 10.
- If there is no room possible in the period the score is assigned a particular number indicating this fact.

7. Output Layout.

Since the program developed is not intended for a final user, the output is not comprehensive. Only the following outputs are provided:

a. Course Assignment.

For every professor-exam unit the following information is printed:

COURSE PROFESSOR ROOM DAY PERIOD.

A sample of the printout is shown in Appendix F.

b. Courses not Scheduled.

A list of unscheduled courses (if any) is given. In case all courses have been scheduled the message is "ALL COURSES SCHEDULED".

c. MOEs.

The measures of effectiveness discussed in Chapter III are evaluated and printed after processing all examinations with each set of coefficients. Only the time of execution MOE1 is not printed.

- MOE2. (Number of seats never used) =
- MOE3. (Number of exams unscheduled) =
- MOE4. (Room adequacy) =
- MOE5. (Exams dispersion in time) =
- MOE6. (Number of back-to-back exams) =

VI. ANALYSIS OF MANUAL AND COMPUTER-ASSISTED SOLUTIONS

WINTER QUARTER 1994.

The problem of final examinations scheduling varies in size from quarter to quarter, but not significantly. The problem changes because the number of students, courses given, professors teaching and room availability can change from one quarter to the next. For the last four years the number of students has remained between 1800 and 2000. The number of professors has not changed substantially, either. The number of courses has a more irregular variation from quarter to quarter. The number of rooms available has very small variations except when a new building is added to the set of academic buildings, as happened in the Winter Quarter of 1993. For all these reasons a specific quarter, the Winter 1994, has been selected to compare the manual and computer-assisted solutions. Also, for policy studies conducted in chapter VII, the problem of the 1994 Winter Quarter is the base. The dimensions of this problem are shown in Section II.C.

A. INPUT DATA

There is no comprehensive computer support for the current scheduling process. Data on the course requests by the students is in a School database but is held only long enough to print reports for the schedulers and then it is destroyed.

The Master Schedule that contains the course and final examination schedule is held briefly in electronic form. The assignment of faculty to courses and special scheduling requests is available only in hand written form. Professor Gordon Bradley with the help of Senior Programming Analyst Lloyd Nolan has developed procedures and a set of programs to capture the data that is available in the mainframe and to enter other data manually. This data was used to produce input files.

B. MODIFICATIONS TO THE INITIAL DATA

In order to facilitate the program implementation, all classroom names are assumed to be composed of 5 characters, the second being a (-). Since some rooms in the data have six character names, such as H-101A, whenever a room contains a trailing alphabetic character, this has been suppressed and the room has been assigned a 5 character designator. To do this a different number has been assigned. For example: rooms H-201E and H-201F become H-200 and H-201 respectively.

C. MANUAL SOLUTION EVALUATION

1. Constraint Violations.

The manual solution has been observed to violate on two occasions the constraint C9, that forbids a professor to have more than one exam during the same period. Two small

courses taught by the same professor were scheduled for the same room (presumable at the professor's request).

2. Time to Get a Solution.

The time estimated to get a solution by the manual method, with two experienced persons working on it, is estimated to be close to five days.

3. MOEs.

The manual solution obtained by the schedulers has been evaluated by the program with the following results:

- MOE2 (number of seats never used) = 177
- MOE3 (number of exams unsolved) = 0
- MOE4 (room adequacy) = 3533
- MOE5 (exams dispersion in time) = 3246
- MOE6 (number of back-to-back exams) = 52

4. Final Examination Distribution Across the Week.

Table 6.1 presents the results obtained by the manual process. Notice the final examination accumulation in the first and third period of each day. Also notice that more final examinations are scheduled at the beginning of the week than at the end. This result, probably coming from a greedy approach, is also observed in the computer-assisted solution. The observed preference of the schedulers for the first and third period of each day is not included in the DESIRABLE FEATURES listed in II.G.

TABLE 6.1 MANUAL SOLUTION:
 NUMBER OF FINAL EXAMINATIONS, ROOMS USED
 AND STUDENTS EXAMINED FOR EACH PERIOD

		MON	TUE	WED	THU
0800	# OF EXAMS	28	28	22	20
1000	# OF ROOMS	35	34	25	26
	# OF STUDENTS	525	515	465	483
1000	# OF EXAMS	4	1	0	1
1200	# OF ROOMS	6	1	0	1
	# OF STUDENTS	102	24	0	24
1300	# OF EXAMS	24	25	15	12
1500	# OF ROOMS	35	36	21	16
	# OF STUDENTS	652	617	447	286
1500	# OF EXAMS	2	7	3	2
1700	# OF ROOMS	2	7	4	4
	# OF STUDENTS	36	71	55	82

D. COMPUTER-ASSISTED SOLUTION EVALUATION

1. Time to Get a Solution.

With the present set of coefficients and the problem conditions of the Winter quarter 1994, five solutions are obtained containing all the courses. Any additional constraint or initial condition could cause a change in the solution. The

current time to run the program for five sets of coefficients is 15 minutes on a PC 486(33).

2. MOEs.

The computer-assisted solution has been evaluated with the same algorithm as the manual solution, obtaining the following results:

- MOE2 (number of seats never used) = 76
- MOE3 (number of exams unsolved) = 0
- MOE4 (room adequacy) = 3094
- MOE5 (exams dispersion in time) = 3193
- MOE6 (number of back-to-back exams) = 110

All MOEs are considered acceptable even though the number of back-to-back exams are more than double the number obtained in the manual solution. The minimization of this figure is a DESIRABLE FEATURE of the program but not a CONSTRAINT. There are no violations to the constraints of the problem.

3. Final Examination Distribution Across the Week.

Table 6.2 shows the distribution of the number of examinations, rooms and students across the 16 periods of the week.

TABLE 6.2 COMPUTER-ASSISTED SOLUTION:
NUMBER OF FINAL EXAMINATIONS, ROOMS USED
AND STUDENTS EXAMINED FOR EACH PERIOD

		MON	TUE	WED	THU
0800	# OF EXAMS	9	8	16	8
1000	# OF ROOMS	23	11	28	9
	# OF STUDENTS	288	196	422	148
1000	# OF EXAMS	29	21	12	0
1200	# OF ROOMS	41	29	15	0
	# OF STUDENTS	617	410	211	0
1300	# OF EXAMS	26	19	11	7
1500	# OF ROOMS	44	33	14	9
	# OF STUDENTS	706	535	208	155
1500	# OF EXAMS	13	9	5	1
1700	# OF ROOMS	18	17	6	1
	# OF STUDENTS	254	202	73	16

E. DIFFERENCES BETWEEN THE MANUAL AND COMPUTER-ASSISTED SOLUTIONS.

There are several notable differences between the manual and the computer-assisted solutions. The heuristics applied in the computer-assisted solution are those used in the manual approach except for the very important fact that the program never reconsiders a previous assignment of exam to a period

and room(s). The schedulers backtrack very often in their search for an optimal solution. This is not easy to do in a practical manner with a programming language not designed for Artificial Intelligence programming. It is evident from observing Tables 6.1 and 6.2 that the greedy approach of both systems lead to an inbalance of exams during the week. Even so, the inbalance is more marked for the computer-assisted solution than for the manual solution. This is explained by the fact that the scheduler can spread the exams once a solution has been reached and the program ends when a feasible solution is reached; no further attempt is made to improve it.

VII. POLICY STUDIES USING THE COMPUTER-ASSISTED METHOD.

A. TWO POLICY STUDIES

Chapter I Section C suggests several policy studies that are possible to do by means of the computer-assisted program.

In the present section two policy studies are explored. The issues for detailed study have been arbitrarily chosen by the author. Thirteen additional policy studies are described in Chapter VIII.

Some of the policy studies require modifying part of the program, others don't. An improved version of the present program could give the user the possibility of testing different policies without entering in the code.

B. RESULTS WITH REDUCTION IN THE NUMBER OF ROOMS

This study is made with two different additional constraints. In the first case a whole floor of Root Hall is suppressed. Root Hall is not considered as critical as other buildings because no curriculum with a large number of students resides in it. This case will decrease by nine the number of classrooms available, with room sizes between 20 and 45 tables. A second test is made cancelling all rooms in the first floor of Glasgow Hall, which is considered to be a critical building with 11 classrooms, with room sizes between

20 and 180 (one with size 20, seven with sizes between 30 and 40, two between 40 and 50, and one with size 180).

1. No Rooms Available in Root Hall.

Five solutions were obtained without modifying the coefficients used for the regular problem. The MOEs obtained and shown in Table 7.1 show little deterioration from the solution shown in Table 6.2. All other conditions are the same as those in the manual solution.

2. MOEs with no Rooms in Root Hall.

- MOE2 (number of seats never used) = 16
- MOE3 (number of exams non solved) = 0
- MOE4 (room adequacy) = 3118
- MOE5 (exams dispersion in time) = 3186
- MOE6 (number of back-to-back exams) = 117

3. Distribution of Exams, Students and Rooms for Every Period.

TABLE 7.1 COMPUTER-ASSISTED SOLUTION:
NUMBER OF FINAL EXAMINATIONS, ROOMS USED
AND STUDENTS EXAMINED FOR EACH PERIOD
WITHOUT ROOT HALL 2nd FLOOR

		MON	TUE	WED	THU
0800	# OF EXAMS	8	11	20	7
1000	# OF ROOMS	22	14	32	7
	# OF STUDENTS	281	206	471	131
1000	# OF EXAMS	25	20	12	1
1200	# OF ROOMS	36	28	14	2
	# OF STUDENTS	573	427	176	27
1300	# OF EXAMS	24	20	13	7
1500	# OF ROOMS	42	34	17	9
	# OF STUDENTS	672	538	255	155
1500	# OF EXAMS	11	8	6	1
1700	# OF ROOMS	16	15	7	1
	# OF STUDENTS	245	181	87	16

4. MOEs with no Rooms on First Floor of Glasgow Hall.

The program was again run using the coefficients reported for the regular problem. The program obtains solutions without violating any constraint for all five sets

of coefficients. The solution considered to have the best MOEs has the following values:

- MOE2 (number of seats never used) = 16
- MOE3 (number of exams non solved) = 0
- MOE4 (room adequacy) = 3047
- MOE5 (exams dispersion in time) = 3167
- MOE6 (number of back-to-back exams) = 106

5. Distribution of Exams, Students and Rooms for Every Period.

TABLE 7.2 COMPUTER-ASSISTED SOLUTION:
NUMBER OF FINAL EXAMINATIONS, ROOMS USED
AND STUDENTS EXAMINED FOR EACH PERIOD
WITHOUT GLASGOW HALL 1ST FLOOR

		MON	TUE	WED	THU
0800	# OF EXAMS	8	16	16	8
1000	# OF ROOMS	21	20	29	8
	# OF STUDENTS	294	266	421	148
1000	# OF EXAMS	25	23	11	1
1200	# OF ROOMS	39	33	15	2
	# OF STUDENTS	572	488	225	27
1300	# OF EXAMS	22	22	11	6
1500	# OF ROOMS	36	39	14	7
	# OF STUDENTS	574	594	201	126
1500	# OF EXAMS	10	10	5	1
1700	# OF ROOMS	18	14	6	1
	# OF STUDENTS	266	148	73	16

C. RESULTS OBTAINED CONVERTING DESIRABLE FEATURE D1 INTO A RIGID CONSTRAINT

It is interesting to test the effects that forbidding back-to-back exams has on the solution. The reason for this interest lies not only in considering the occurrence of back-

to-back exams a very important inconvenience. If imposing this rigid constraint causes a certain number of examinations not to be scheduled, it could be suspected that student conflicts are the most critical factor in the current problem. Acceptable solutions were obtained despite the suppression of 12 classrooms considered critical because their size and location. This showed that classroom availability in the present situation is far from being critical. If the test now conducted is not able to construct solutions as good as those obtained in Section B of this Chapter we could conclude that student conflicts are more critical than classroom availability.

Running the program with the same complexity coefficients mentioned in Chapter V, none of the five sets of coefficients was able to get a solution containing all the courses. The best solution was unable to schedule six courses.

1. MOEs with no Back-to-back Exams Permitted.

The MOEs obtained differ from those in the regular problem in an improvement in the number of seats never used, a deterioration in rooms assignment adequacy, an improvement in time distribution along the week and of course a total improvement in number of back-to-back exams since this is the new constraint imposed. The time of execution is not significant and is of the same order as all previous executions. The results are:

- MOE2 (number of seats never used) = 146
- MOE3 (number of exams non solved) = 6
- MOE4 (room adequacy) = 2987
- MOE5 (exams dispersion in time) = 3228
- MOE6 (number of back-to-back exams) = 0

Since 6 exams have not been scheduled, the program can be executed again with exception E1 in force, allowing exams to be scheduled on Friday.

2. Distribution of Exams, Students and Rooms for Every Period.

Table 7.3 shows the distribution of final examinations obtained when no back-to-back examinations are permitted. There are three periods with no examinations assigned and as a consequence the other periods contain a greater number of examinations than in previous schedules.

TABLE 7.3 COMPUTER-ASSISTED SOLUTION:
 NUMBER OF FINAL EXAMINATIONS, ROOMS USED
 AND STUDENTS EXAMINED FOR EACH PERIOD
 WITH NO BACK-TO-BACK EXAMS PERMITTED

		MON	TUE	WED	THU
0800	# OF EXAMS	13	8	14	7
1000	# OF ROOMS	26	19	25	10
	# OF STUDENTS	335	397	387	166
1000	# OF EXAMS	18	18	9	7
1200	# OF ROOMS	24	29	11	9
	# OF STUDENTS	345	401	143	109
1300	# OF EXAMS	35	32	14	12
1500	# OF ROOMS	49	53	19	15
	# OF STUDENTS	1035	808	303	226
1500	# OF EXAMS	1	0	0	0
1700	# OF ROOMS	1	0	0	0
	# OF STUDENTS	1	0	0	0

VIII. CONCLUSIONS

A. ACHIEVEMENT OF THE GOALS

1. Shorten Time.

The time required by the program to produce a solution is variable depending on the input data and the set of coefficients used. For the 1994 Winter Quarter, the time needed by a 486 DX(33) personal computer has been approximately 15 minutes. However, this does not provide a good indication of the time required to find an acceptable solution. With different data and constraints it could be necessary to carry out a process of coefficient adjustment to evaluate course scheduling complexity and also adjust the weight given to every factor influencing the period ranking process. Both processes are not so complex as one would first think. The coefficients that have the most influence in complexity evaluation are those containing the number of remaining conflicts. When adjusting period ranking weights it is recommended to start modifying only that of the number of back-to-back exams in the period. In all, if the process is conducted with small variations (about 10 %) of the current values, and one by one, a process estimated to take 3 hours can produced an acceptable solution.

2. Improve Quality.

The quality of the solutions obtained with the computer application are not as good as the solution obtained by the manual solution, except in time to get a solution. Therefore, it is thought that a good use of the program could be to generate a solution from which to start a manual process of improvement, leading to the levels of quality achieved by the manual solution, but possibly in a much shorter time.

3. Policy Studies.

Two studies have been conducted, the first tested two important, but not simultaneous, reductions in the number of rooms available for final examinations. In both reduction cases, the program was able to find several solutions in a very short time. The quality of the solutions was similar to that of the Winter Quarter problem solved in Chapter VI, without any important deterioration in the MOEs. The time of execution was similar, and therefore it is concluded that the programs gives a good tool to test different classrooms availability hypotheses. The second policy study tries to find an schedule without back-to-back exams. The best solution containing no back-to-back exams is unable to schedule six exams.

B. POSSIBLE IMPROVEMENTS TO THE HEURISTIC

There are some possibilities to improve the heuristic that have not been tested. The schedulers, in their heuristic manual method, preschedule some examinations known from past experience to be the cause of a great deal of difficulty. If those examinations are manually prescheduled in the computer-assisted procedure, a better solution may be obtained. Other possible improvements consist in determining those examinations containing students with 4 or more examinations and giving them the highest priority to be scheduled. Also, a more detained search for adequate coefficients, both to evaluate scheduling complexity and to rank periods, could yield improved results.

Another way of improving the solution obtained is to apply a process of local search. By this process every possible interchange of two exams is studied, and if some benefit is obtained, the change is performed. This process can then be repeated until no improving-interchange can be found.

Heuristic methods such as simulated annealing and tabu search could also be used to improve the solution [Ref.15] and [Ref.16].

C. FUTURE POLICY STUDIES

The computer-assisted method developed in this thesis should permit consideration of some policy issues that require the construction of schedules under different assumptions.

These studies are not possible by manual methods given the length of time required to get a solution.

1. Graduating Students

Currently the information available to the schedulers does not contain an exact indication of which courses contain students who graduate in that final examination week. The knowledge of this data is important given constraint C13 which forbids graduating students to make final exams on Thursday morning. The schedulers currently have to guess which courses have graduating students. They typically designate any student taking a thesis slot and only 3000 or 4000 level courses as graduating. This guess imposes an unnecessary restriction since many students in addition to those graduating can satisfy it. In the present research a study has been made to determine which courses contain graduating students. It is of interest how that increased accuracy in the input data affects the output.

2. Courses not Holding a Final Examination

Currently not all courses which have a final examination scheduled really hold it at the end of the course. Sometimes the professor replaces the final examination requirement by some other equivalent requisite, for example a paper, presentation, etc.

If these courses were known exactly and in time for the schedulers to remove them from the list of courses requiring final examination, the problem would be simplified.

3. Impact of Final Examinations for all Courses

In the winter quarter of 1994, 68.5% of the courses required final examinations. It is interesting to know if it is feasible with the current constraints to construct a final examination schedule containing all the courses in the quarter, or if it is necessary to modify those requirements and in what way.

4. Impact of Refresher Courses

The refresher courses are held up to and including the final examination week. It is possible for a professor to have both refresher course lectures and final examination during the final examination week. A student may also have a refresher class and one or more final examinations. The impact of this on the solution is of interest; it could influence the refresher courses schedule. Classrooms used by refresher courses put an additional constraint on room availability that is worth studying.

5. Impact of Delaying Final Examination Scheduling

At the time the final examination is produced, in the present manual solution situation, the courses that every student is going to take during the next quarter is not definitely determined. Students have the opportunity to modify

their program during the first two weeks of the quarter. The proportion of students that made some kind of modification to their programs during the first two weeks of the 1994 winter quarter was approximately 30%. The possible conflicts that arise in the final examination schedule because of these modifications are dealt directly by professor and students. If the final examination scheduling could be postponed until after the second week of a quarter, better information on students course enrollment would be available and these late modifications could be taken into account.

6. Identify Quality Measures

The computer-assisted scheduling provides a means to study the sensitivity of different measures of effectiveness to different input. Some MOEs of interest are difficult to obtain from the manual solution. It is easier to construct statistical measures with a computer program than request it from the schedulers.

7. Impact of Using Three Non-consecutive Periods a Day

Currently four exam periods a day are being used by the schedulers and these are also the periods used by the program developed in this thesis. This is not a rigid constraint but a convention adopted by the schedulers. The two hour periods currently used begin at 0800, 1000, 1300 and 1500. Since both professors and rooms require at least an empty period of one hour between exams, this means that both

can be scheduled at most two examinations a day, one in the morning and another in the afternoon. The benefit of the present plan is related to students conflicts, since it offers four periods in which to solve students exam conflicts. This is only partially true. Students can be scheduled for back-to-back exams, although this is considered a bad solution; but they cannot be assigned more than two examinations in a day. So assigning to a student two examinations in the morning, not only penalizes the quality of the schedule but it also prevents any examination for them to be scheduled in the afternoon. Given the daily time frame of 0800-1700, it might be better to work with three non-consecutive periods a day, that is: 0800-1000, 1100-1300, 1400-1600. Another interesting possibility to explore is the benefits given by an increase of two hours in the daily time frame, such that permits examinations to end at 1900. This would permit four periods a day without any back-to-back examinations for any students.

8. Degree of Room Utilization

It is important to know the degree of room utilization for each room size and for every department to determine future policies of increasing or decreasing the number of rooms and to determine what size of room is needed most.

9. Impact of Using Additional Spaces

Tests can be conducted with the computer-assisted method to determine the impact of adding additional spaces

such as study rooms, laboratories or conference rooms, to the list of rooms available for final examinations.

10. Impact of Non-simultaneity for all Segments of a Course.

One of the constraints implemented currently is that which requires all segments of a course to have their final examination scheduled at the same time. What would be the impact of a relaxation of this constraint on the solution? Modifying this constraint in the program is easy to do.

11. Impact of Students with More Than Four Examinations

The schedulers believe [Ref.7], that the few students who have five or more final examinations, cause a large increase in the difficulty of the scheduling problem. It is of interest to evaluate this impact by constructing a solution that limits the maximum number of examinations allowed.

12. Effect of Different Periods each Day

Since the difficulty to get a solution sometimes comes from a room limitation, sometimes by students conflicts and sometimes by the no back-to-back constraint concerning professors and classroom use, it could be of interest to test the impact of keeping some days with four periods, two in the morning and two in the afternoon, and one or two days with a three non-consecutive periods schedule. This schedule would decrease the total number of periods available, but would increase the permitted room use from two in a day to three in

a day. The same is applicable to the number of final examinations a professor could be assigned in a day.

13. Impact of Changes in the Number of Students.

A simplistic approximation to future increases in the number of students can be done by increasing in the same proportion the number of students in every course and assigned to every professor. For a better study it would be, probably, necessary to increase the number of professors teaching some courses.

APPENDIX A: GLOSSARY OF TERMS

Back-to-back exams - Two exams held in consecutive periods.

Best period - The period available to schedule an exam in which the partial MOE is optimized. This does not necessarily give the best MOEs for the total scheduling solution.

Classroom exam capacity - The real capacity of a room divided by 1.5.

Classroom period - A two hour period in which a classroom can be scheduled for an exam.

Conflicting courses - Two courses conflict if they contain at least a common student or are taught by the same professor.

Course - A discipline taught by one or more professors, in one or more rooms, and requiring a final examination.

Course-scheduler - The person(s), assigned to the Registrar's Office, in charge of constructing the final exams schedule.

Course Segment - When the number of students taking a course make it necessary to divide them in smaller groups with different professors and different times or rooms, or the same professor and different times, each group of students assigned to a professor in a period constitutes a "Course Segment".

Examination - The time period, professors and classrooms that define when, where and by whom an exam is going to be taken.

At this period of time all professors teaching this course should be free of other commitments. Classrooms should be available for every Professor-Exam. All students taking this exam should be free of other obligations.

Examination complexity number - Figure indicating the difficulty of scheduling an exam in relation with others.

Examination Period - A period of two hours assigned to take an exam of a course. It needs to be between 0800 and 1700 of the days (Monday through Thursday) assigned for Final Examinations.

Final exams week - The four days(Monday through Thursday) of the twelfth week of a quarter in which Final Exams are held.

Floor - The set of classroom in the same floor of an academic building. Two or more classroom in the same floor are considered to be close to each other and are valid for professor-exam assignment.

Group conflict - The situation produced when trying to schedule an exam in a determined period and another exam has been previously assigned to the same period for some of the student group participating in the exam.

Instructor Schedule Card - A 5" x 8" card on which the schedule of classes of a faculty member for the next quarter is written. There is one for every faculty member with lectures assigned during next quarter.

Lecture Classroom - The classroom in which a Course Segment takes the lectures during the quarter.

Preassigned period - An exam for which a special requirement of period time has been requested.

Preassigned room - An exam for which a special requirement of classroom has been requested.

Professor-exam - The exam that a professor gives to all the segments of one course he/she is teaching. It requires a classroom or set of classrooms independent of other Professor-exams, even in the same course.

Professor-Exam Classroom - A set of classrooms assigned to a professor during an exam period for all his students of the same course, (could belong to one or more segments).

Regular classroom and Laboratory Schedule Card - A 5" x 8" card on which the schedule of classes held in the classroom for that quarter is written. There is one for every classroom.

Room available - The situation relative to a classroom that is available at a period for an exam and has at least one hour of no use immediately after the exam.

Solution - The set of all exams with their professors, classrooms and periods.

Solution value - The Measure of Effectiveness of the solution found.

Student clique - A group of students in the same curriculum who take the same courses during the quarter.

Student Schedule Card - A 5" x 8" card on which the schedule of classes of a student clique for the next quarter is written. All students in the same clique have identical

Student Schedule Cards and therefore only one Card is made containing the names of all students concerned. A copy is made for each student concerned.

Unscheduled exam - An examination which has not been possible to schedule.

APPENDIX B: ACADEMIC DEPARTMENT DESIGNATORS

Administrative Sciences	AS
Service Courses	
Telecommunications Systems Management	CM
Information Systems	IS
Management	MN
Aeronautics and Astronautics	AE
Antisubmarine Warfare	ST
Command, Control and Communications	CC
Computer Science	CS
Electrical and Computer Engineering	EC
Electronic Warfare	EW
Interdisciplinary Courses	EO
Mathematics	MA
Mechanical Engineering	ME
Materials Science	MS
Meteorology	MR
National Security Affairs	NS
Oceanography	
Oceanographic Sciences	OC
Hydrographic Sciences	GH
Operations Research	
Operations Analysis	OA

Service Courses	OS
Physics	PH
Science and Engineering	SE
Space Systems	SS

APPENDIX C: FLOOR PREFERENCES BY DEPARTMENT

Sequence of floor preferences for each department in decreasing order of preference. The preferences are indicated by two characters the first one indicates the building and the second one indicates the floor in that building. The building indicators are:

H = Halligan Hall,

B = Bullard Hall,

R = Root Hall,

I = Ingersoll Hall,

S = Spanagel Hall,

G = Glasgow Hall,

The preferences are:

<u>DEPARTMENT DESIGNATOR</u>	<u>PREFERENCES</u>
AA	H1,H2, B1, B2, R2, R1, I1, I2, I3, S2, S3, S4, S1, G0, G1, G3.
AS	I1, I2, I3, R2, R1, GB, G1, G3, S2, S3, S4, S1, H1, H2, B1, B2.
CM	S3, S2, S4, S1, R2, R1, B1, B2, H1, H2, I2, I3, I1,G1, GB, G3.
IS	I1, I2, I3, S4, S3, S2, S1, GB, G1, G3, R2, R1, H1, H2, B1, B2.

MN I2, I3, R2, GB, G1, G3, R2, R1, H1, H21, B1, B2,
S2, S3, S4, S1.

AE H1, H2, G1, G2, R2, R1, I1, I2, I3, S2, S3, S4,
S1, GB, G1, G3.

ST S3, S2, S4, S1, R2, R1, B1, B2, H1, H2, I2, I3,
I1, GB, G1, G3.

CC R2, R1, S3, S2, S4, S1, H1, H2, B1, B2, I2, I3,
I1, G1, GB, G3.

CS S4, S3, S2, S1, R2, R1, B1, B2, H1, H2, I2, I3,
I1, G1, GB, G3.

EC S3, S2, S1, S4, R2, R1, B1, B2, H1, H2, I2, I3,
I1, G1, GB, G3.

EW S3, S2, S4, S1, R2, R1, B1, B2, H1, H2, I2, I3,
I1, G1, GB, G3.

EO S3, S2, S4, S1, R2, R1, B1, B2, H1, H2, I2, I3,
I1, G1, GB, G3.

MA G1, GB, G3, I2, I3, R2, R1, I1, S2, S3, S4, S1,
H1, H2, B1, B2.

ME H1, H2, B1, B2, R2, R1, S2, S3, S1, S4, GB, G1,
G3, I2, I3, I1.

MS S2, S1, S3, S4, R2, R1, B1, B2, H1, H2, I2, I3,
I1, G1, GB, G3.

MR R2, R1, I2, I3, GB, G1, G3, I1, S2, S3, S4, S1,
H1, H2, B1, B2.

NS GB, G1, G3, R2, R1, I2, I3, I1, S2, S3, S4, S1,
H1, H2, B1, B2.

OC S2, S3, S4, S1, R2, R1, I3, I2, I1, H1, H2, GB,
G1, G3, B1, B2.

GH R2, R1, I2, I3, GB, G1, G3, I1, S2, S3, S4, S1,
H1, H2, B1, B2.

OA GB, G1, G3, I2, I3, R2, R1, I1, S2, S3, S4, S1,
H1, H2, B1, B2.

OS GB, G1, G3, I2, I3, R2, R1, I1, S2, S3, S4, S1,
H1, H2, B1, B2.

PH S1, S2, S3, S4, R1, R2, B1, B2, H1, H2, I3, I2,
I1, GB, G1, G3.

SE S1, S2, S3, S4, R1, R2, H1, H2, B1, B2, GB, G1,
G3, I3, I2, I1.

SS R1, R2, H1, H2, B1, B2, S1, S3, S4, GB, G1, G3,
I2, I3, I1.

TS S2, S3, S4, S1, R2, H1, H2, B1, B2, GB, G1, G3,
I3, I2, I1.

APPENDIX D: HIGH LEVEL FLOW CHART OF THE PROGRAM

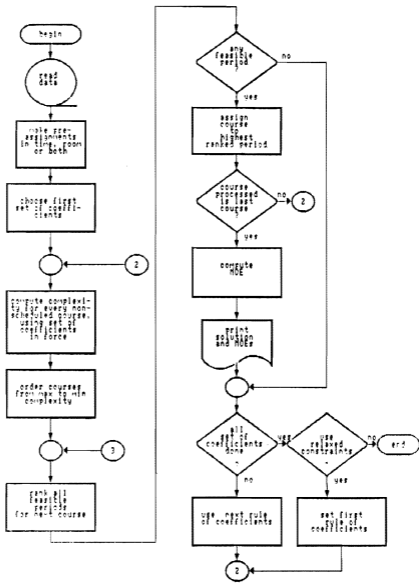

APPENDIX E: PERIOD RANKING FLOW CHART

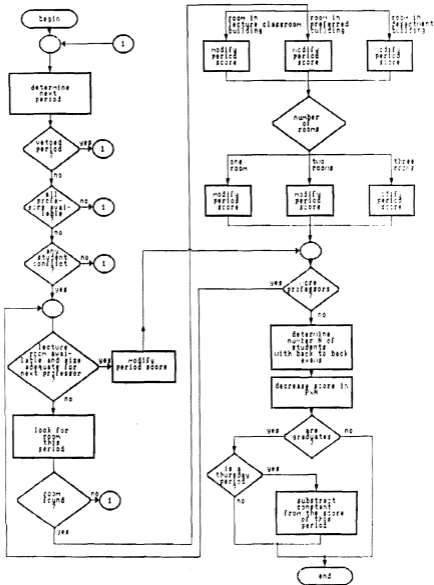

APPENDIX F: PARTIAL SOLUTION OUTPUT

SCHEDULE FOR THE SET OF COEFFICIENTS # 1

COURSE = NS3252; FACULTY = NS/HL; PERIOD = monday 0800-1000
ROOM 1 = G303; ROOM 2 = G306; ROOM 3 = G386

COURSE = NS3252; FACULTY = NS/TT; PERIOD = monday 0800-1000
ROOM 1 = I260; ROOM 2 = I263

COURSE = NS3252; FACULTY = NS/JO; PERIOD = monday 0800-1000
ROOM 1 = G387; ROOM 2 = G388; ROOM 3 = G389

-(ALL OTHER COURSES, FACULTY, PERIOD AND ROOM ASSIGNMENTS)-

MEASURES OF EFFECTIVENESS

MOE2, NUMBER OF SEATS NEVER USED = 76
MOE3, NUMBER OF NON SOLVED EXAMS = 0
MOE4, MEASURE OF ROOM ADEQUACY = 3094
MOE5, EXAMS DISPERSION IN TIME = 3193
MOE6, NUMBER OF BACK TO BACK EXAMS = 110

REFERENCES

- [1] Opanavinst 5450.210B.
- [2] Nolan, S. Jeffrey and Youngblood, D. Phillip, "Naval Postgraduate School Scheduling Support System (NPS)" Master's Thesis, Naval Postgraduate School, Monterey, California, March 1992.
- [3] Naval Postgraduate School Technical Note No 0211-01. The Heuristic Academic Master Scheduler, 1966.
- [4] Fiegas, W. Dietmar, "The Naval Postgraduate School Scheduling System: A Heuristic Approach", Master's Thesis, Naval Postgraduate School, Monterey, California, September 1985.
- [5] Broder, S. "Final Examinations Scheduling", *Communications of the ACM*. vol 7, 1964, pp. 494-498.
- [6] Conversation with Mrs Edith Phillips 21 October 1993.
- [7] Conversation with Mrs Edith Phillips 7 December 1993.
- [8] Conversation with Mrs Edith Phillips 7 January 1994.
- [9] Conversation with Mr Lloyd Nolan 24 November 1993.
- [10] Eglese, R.W. and Rand, G.K, "Conference Seminar Timetabling". *Journal of the Operational Research Society*, vol.38, 1987, pp. 591-598.
- [11] Johnson David, "Timetabling University Examinations", *Journal of the Operational Research Society*, vol 41, 1990, pp. 39-47.
- [12] Carter, W. Michael, "A Survey of Practical Applications of Examination Timetabling Algorithms", *Operations Research*, vol 34, 1986, pp. 193-202.
- [13] Carter, W. Michael and Tovey, A. Craig, "When is the Classroom Assignment Problem Hard?", *Operations Research*, vol 40, 1992, pp. s28-s39.
- [14] Kirkpatrick, S., Gelatt, C.D. and Vecchi, M.P., "Optimization by Simulated Annealing", *Science*, 13, May 1983, vol 220, pp. 671-679.

[15] Dell, F. Robert, Kemple, G. William and Tovey, A. Craig, "Heuristically solving the stratigraphic correlation problem", Institute of Industrial Engineers, *First Industrial Research Conference Proceedings, 1992*, pp. 293-297.

INITIAL DISTRIBUTION LIST

	No. Copies
1. Defense Technical Information Center Cameron Station Alexandria VA 22304-6145	2
2. Library, Code 052 Naval Postgraduate School Monterey CA 93943-5002	2
3. Prof. Gordon H. Bradley, Code OR/BZ Department of Operations Research Naval Postgraduate School Monterey CA 93943-5002	4
4. Prof. Robert F. Dell, Code OR/DE Department of Operations Research Naval Postgraduate School Monterey CA 93943-5002	2
5. Mr. Tracey Hammond, Code 61 Registrar Naval Postgraduate School Monterey CA 93943-5002	1
6. Mr. Richard S. Elster, Code 06 Dean of Instruction Naval Postgraduate School Monterey CA 93943-5002	1
7. Prof. Maurice Weir, Code MA/WC Department of Mathematics Naval Postgraduate School Monterey CA 93943-5002	1
8. Pedro F. Golmayo, Capitan de Corbeta GIMO Cuartel General de la Armada, Montalban 2 Madrid Spain	2

DUDLEY KNOX LIBRARY
NAVAL POSTGRADUATE SCHOOL
MONTEREY CA 93943-5101

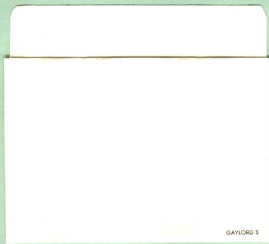

GAYLORD S

DUDLEY KNOX LIBRARY



3 2768 00098866 1